

the other of the two fundamental factors which are being recognized in explaining the properties of solutions, namely, the formation of compounds, and the breaking down of complex molecules present in the liquids.

Summary

1. An electrical resonance method, making use of several novel features, for the determination of the dielectric constants of liquids has been presented.

2. The dielectric constants at 25° of pure benzene, toluene, carbon tetrachloride, bromobenzene and chlorobenzene have been redetermined. A new value, and it is believed a more exact one, has been found for chlorobenzene.

3. The dielectric constants of three binary mixtures at 25° have been determined at various concentrations. The systems studied are benzene-toluene, benzene-carbon tetrachloride and chlorobenzene-bromobenzene, all of which may be considered as being nearly ideal solutions.

4. Each of the systems studied has been critically discussed, and an attempt made to explain the nature of the changes taking place on solution, from a consideration of values of the dielectric constants of the solutions.

MADISON, WISCONSIN

[CONTRIBUTION FROM THE NATIONAL BUREAU OF STANDARDS, UNITED STATES
DEPARTMENT OF COMMERCE]

THE RATE OF FLAME PROPAGATION IN GASEOUS EXPLOSIVE REACTIONS¹

BY F. W. STEVENS

RECEIVED APRIL 30, 1926

PUBLISHED JULY 6, 1926

In the case of gaseous explosive reactions the energy transformation of the chemical system is brought about by the spatial propagation within the explosive gases of a thin, sharply defined area of reaction marked by flame.² The expression, then, rate of flame propagation, should refer to the linear rate of displacement of this area relative to the active gaseous components in which it propagates itself. This rate may be expressed by

$$s = v_p/ta \quad (1)$$

where v_p is the volume at constant pressure of the active components passing an element of the flame front in time t ; a is the area of this element.^{3,4,5,6}

¹ Published by permission of the Director of the National Bureau of Standards of the U. S. Department of Commerce.

² Luther, *Z. Elektrochem.*, **12**, 597 (1906).

³ Bunsen, *Phil. Mag.*, **34**, 1 (1867).

⁴ Gouy, *Ann. chim. phys.*, [5] **18**, 18 (1879).

⁵ Michelson, *Ann. Phys. Chem.*, **37**, 1 (1887).

⁶ Mache, "Die Physik der Verbrennungserscheinungen," Viet and Co., Leipzig,

Haber^{7,8} recognizes three well-defined zones in the progress of a gaseous explosion: the region occupied by the explosive gases within which the zone of reaction, marked by flame, propagates itself; the region of the flame within which the explosive reaction is initiated and, for the conditions there prevailing, completed; and the region occupied by the equilibrium products of the reaction behind the flame. "This region," he states, "is not, from a thermodynamic standpoint, free from oxygen, but from an analytical standpoint it is. In this region no further burning takes place." The expression for this equilibrium condition is given by the equilibrium constant,

$$K = \frac{[A]^{n_1} [B]^{n_2} [C]^{n_3}}{[A']^{n'_1} [B']^{n'_2} [C']^{n'_3}} \quad (2)$$

It is found possible by other devices than a burner so to condition a gaseous explosion that these zones shall maintain, during the explosive reaction, definite geometrical forms and relative positions of symmetry, with a high degree of precision. With especial reference to the rate of flame propagation in explosive gaseous reactions, it is the purpose of this paper to describe a simple device and method based largely upon this symmetry and found applicable both to thermodynamic and kinetic studies of the explosive gaseous reaction. Both the method and device to be described are the direct outgrowth, as will be seen, of the important series of thermodynamic studies begun by Langen⁹ and extended by Pier,¹⁰ Bjerrum,¹¹ and Siegel,¹² in which the gaseous explosive reaction was first successfully employed as a method of precision to determine the specific heat of gases at high temperatures; also to determine the degree of dissociation over wide ranges of temperature and pressure; of the important products of combustion, carbon dioxide and water vapor. The accuracy of the experimental method developed by these investigators depends in large part upon so conditioning the explosive reaction that the heat losses during the process shall be reduced to a minimum. The device employed by them was a spherical bomb of constant volume fired from the center. By this arrangement the three zones mentioned by Haber are maintained concentric with the spherical bomb throughout the reaction; the central sphere of equilibrium products originating at the center is thus protected from heat losses due to conduction and convection until the end of the reaction when the flame area that encloses them reaches the walls of the bomb. In case the flame movement within the bomb has not been more rapid than the rate of pressure distribution within the gases, a Pier manometer at

⁷ Haber, *Z. physik. Chem.*, **68**, 726 (1909).

⁸ Hiller, *ibid.*, **81**, 591 (1912).

⁹ Langen, *Mitt. Forsch. arbeit.*, **8**, 1 (1903).

¹⁰ Pier, *Z. Elektrochem.*, **15**, 536 (1909).

¹¹ Bjerrum, *Z. physik. Chem.*, **79**, 513 (1912).

¹² Siegel, *Z. physik. Chem.*, **87**, 641 (1914).

the surface of the bomb registers the maximum pressure at the completion of the reaction. This pressure is identified with the equilibrium condition of the reaction products (Equation 2) and, as Siegel has shown for the case of such trimolecular reactions as $2\text{CO} + \text{O}_2$ and $2\text{H}_2\text{O} + \text{O}_2$, it is identified with the degree of dissociation, x , of the combustion products.

$$K = \frac{[\text{CO}]^2 [\text{O}_2]}{[\text{CO}_2]^2} = \frac{x^3}{(1-x)^2 \left(1 + \frac{x}{2}\right)} \times \frac{P}{2RT} \quad (3)$$

Although these investigations were concerned with the thermodynamics of the reaction, the reaction rate was, nevertheless, always a major factor in the practical application of the method and determined its limitations.

Since it was assumed that the readings of a manometer—at least for moderate explosion rates—could give a reliable time-pressure record of the reaction, this, in connection with the fact that the area of reaction assumed the form of an expanding spherical shell concentric with the bomb, led to numerous involved attempts to deduce from the time-pressure record of a manometer the movement of the flame within the bomb.^{13,14}

Since these theoretical deductions were unrelated to the principles of chemical kinetics and lacked direct experimental proof, the writer attempted to follow the flame movement within the bomb by making use of the photographic method developed by Dixon¹⁵ in his work on flame movement within cylindrical containers. A spherical bomb of glass was used instead of steel. This device proved unsatisfactory although experience with it was convincing of the futility of the use of manometric methods in connection with time intervals approaching those met with in the study of sound phenomena, as is the case when resonance or impact waves develop within the bomb.

An attempt was then made to use a soap film container fired from the center. The use of this simple and easily manipulated device in connection with photographic methods revealed not only the accurate symmetry maintained by the transforming zones during the reaction, shown in Fig. 3, but showed also that at constant pressure, the rate of flame propagation within the explosive gases remains constant during the reaction. A constant rate of supply at a constant concentration of the active components to the flame area would seem to indicate the maintenance of a constant condition within or a constant gradient across the zone of reaction as well as a constant equilibrium condition of the reaction products leaving the flame. The photographic records show only a decrease in the volume of equilibrium products after the flame has passed.

This device, for explosion rates not too near the velocity of sound in the

¹³ Nägel, *Mitt. Forsch. arbeit.*, **54**, 1 (1908).

¹⁴ Flamm und Mache, *Akad. Wien. Ber.*, [IIA] **126**, 9 (1917).

¹⁵ Dixon, *Phil. Trans.*, R. S., **200**, 315 (1903).

gases, functions as a bomb of constant pressure¹⁶ and in this respect provides the complement to the bomb of constant volume. For a study of a number of explosive gaseous reactions it has the advantage over a bomb of constant volume of dispensing with a manometer; of maintaining constant the concentrations of the explosive gases the flame is entering till the end of the reaction; and, being transparent, it permits a direct and accurate photographic time-volume record of the reaction to be secured; whereas a time-pressure record sought by the use of a manometer involves indefinite changes in the concentrations of the gases due to inconstant pressure during the reaction.

The bubble device also readily permits the effect of pressure upon the rate of flame propagation to be observed. For this purpose it is enclosed within a sufficiently large and strong air-tight chamber also of spherical form, where the reaction may run its course at a pressure practically constant either below or above atmospheric.

A number of simple gases, together with mixtures of simple gases both active and inert, have been investigated during the past few years by the method more fully described below. Besides other interesting characteristics of flame behavior, a study of the photographic time-volume records obtained has shown that a definite relation exists between the movement of the flame area and the initial concentrations of the active gaseous components within which it propagates itself. This relation may be expressed as

$$s = \frac{v_p}{ta} = k_1 [A]^{n_1} [B]^{n_2} [C]^{n_3} \quad (4)$$

where k_1 is a proportionality factor. The experimental results offered to illustrate this relationship are drawn from a study of the explosive reaction

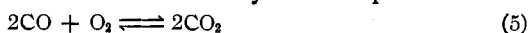

at water-vapor saturation and at atmospheric pressure.

Experimental Part

A bubble, b , see Fig. 1, of convenient size, is blown with a mixture of the explosive gases, carbon monoxide and oxygen, whose partial pressures are known. Through the aperture from which the bubble is blown is inserted an ignition gap c to the center, as near as may be, of the bubble. Back of the bubble is placed a black, opaque screen, o, o , provided with a narrow horizontal slit that can be illuminated. This slit falls in the same horizontal plane as c . A camera whose sensitive film is attached to a rotating drum f , is focused on c and the outlying edges of the bubble at either side of c . While the drum is at rest and the translucent slit illuminated, an exposure is made securing a silhouetted image of c and the edges of the bubble. This record compared with the photographic record of a milli-

¹⁶ Nat. Advisory Committee for Aeronautics, Rept. No. 176 (1923).

meter scale in the same position gives the diameter of the sphere of explosive gases to be considered—and this irrespective of the actual shape of

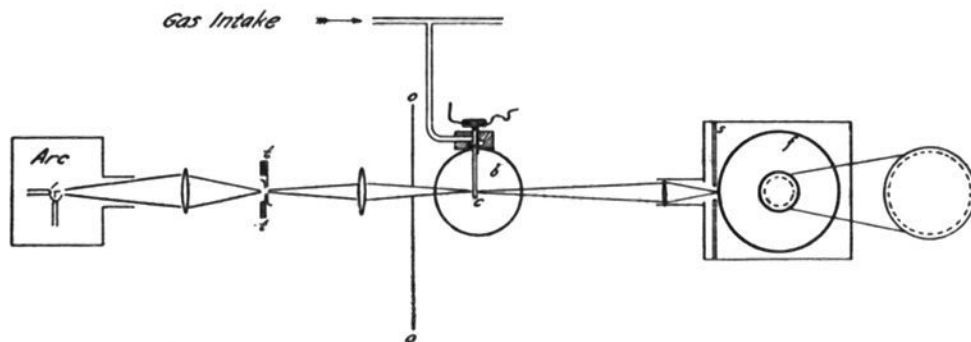

Fig. 1.—The arrangement of apparatus: *b*, bubble holding explosive gases; *c*, ignition gap; *o*, screen; *t*, tuning fork with shutters; *f*, rotating drum carrying sensitive film; *s*, screen with narrow horizontal opening.

the bubble which is never a sphere. A record showing the appearance of this dimension is shown at 7 and 8, Fig. 2. The illumination behind *o*, *o*, is now turned off; the drum *f*, bearing the photographic film, is set in rotation, the cap of the camera removed and an ignition spark passed. The record of this spark on the photographic film marks the center of the spherical, expanding area of reaction. Only the horizontal motion of this flame area is allowed to reach the photographic film. This is accomplished by interposing between the lens and as close as possible to the photographic film, a second screen, *s*, with a narrow horizontal aperture. The horizontal motion of the flame area and the motion of the photographic film are at right angles to each other so that the flame trace on the film is the resultant of these two motions. The inclination of the flame trace to the horizontal gives the velocity of the flame movement *in space* at any instant during its progress—provided the velocity of the film during the reaction is known. The velocity of the film during the explosion is determined in the following way: The narrow aper-

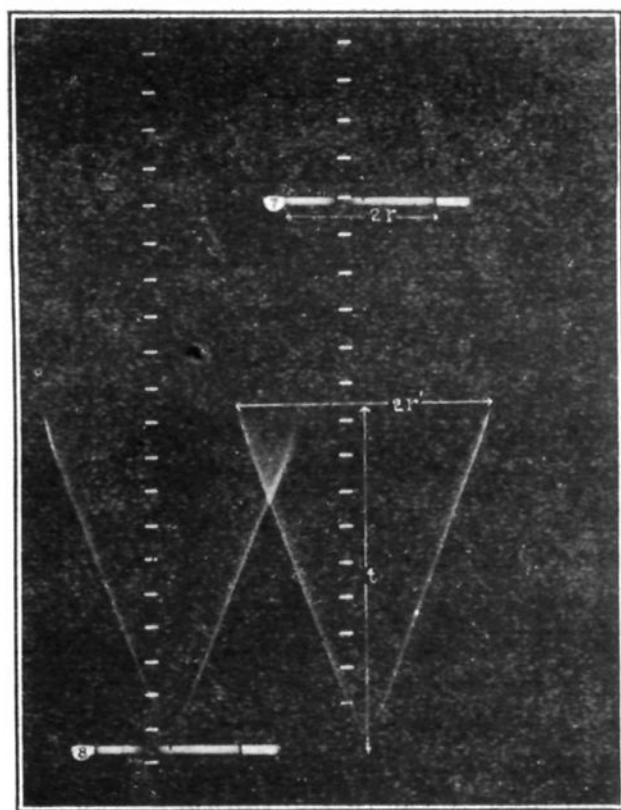

Fig. 2.—A photographic record of two observations of the same explosive gases; $2r$, initial diameter of gaseous sphere before reaction; $2r'$, final diameter of gaseous sphere at instant reaction is completed; t , interval of reaction.

velocity of the film during the reaction is known. The velocity of the film during the explosion is determined in the following way: The narrow aper-

ture in the shutters of a calibrated tuning fork, t , t , is placed at one side of and close to the optical axis of the camera passing through c . This aperture is brightly illuminated by an arc. An image of this illuminated aperture is formed in space at one side of and in the same vertical plane as c . When the fork is vibrating this image is intermittent at twice the normal frequency of the fork. These flashes are recorded on the rotating sensitive film during the progress of the explosive reaction. A device attached to the drum of the camera prevents the time record continuing longer than one revolution of the drum.

The diameter of the gaseous sphere of initial components considered is given by the photographic record $2r$, Fig. 2; the final diameter of the sphere of equilibrium products, by $2r'$. Since the velocity of the flame, under the condition of constant pressure, is constant, its velocity *in space*, s' , may be found at any convenient position on the photographic record between the initial and end-point of the reaction. At the end of the reaction its value may be expressed in terms of r' ,

$$s' = r'/t \quad (6)$$

The velocity, s , of the flame relative to the explosive gases in which it is propagated, is given for the case where the zone of reaction is an expanding spherical shell, by

$$s = \frac{v_p}{ta} = s' \frac{r^3}{r'^3} = \frac{r^3}{r'^3 t} \quad (7)$$

Results

The value of s was determined by the method described for a large number of different partial-pressure combinations of the gases carbon monoxide and oxygen at water-vapor saturation. These values covered practically the entire range of mixtures of these gases that would ignite. Fig. 3, by the solid circles, expresses graphically the relation between the rate of flame propagation within the gases and the corresponding initial partial pressures of their active components. The graph readily suggests a distribution curve; and since the results show that the rate of propagation of the zone of reaction with the explosive gases is related to their concentrations, a trial was made to see whether this rate was proportional to the product of their concentrations.

$$s = k_1 [\text{CO}]^2 [\text{O}_2] \quad (8)$$

In order to test this expression, the experimental values of s together with the corresponding partial pressures of the active gases were arranged as shown in Table I.

The value of k_1 is shown by the photographic records to remain constant during each reaction. It is shown by the table to remain fairly constant over the entire range of mixtures of the gases that will ignite. Using the average value of k_1 as given in the table to compute s in the expression

TABLE I

OBSERVED FLAME VELOCITIES OF THE CO, O₂ EXPLOSIVE REACTION

Record No.	Partial pressure [CO] [O ₂]		$s' = \frac{r'}{t}$ cm./sec.	$s = s' \frac{r^2}{r'^2}$ cm./sec.	Mean value S	$k_1 = \frac{s}{[\text{CO}]^2 [\text{O}_2]}$
1	0.241	0.759	126	31.7		
2			127	30.7		
3			131	30.8	31.1	703
15	.305	.695	282	41.6		
16			289	41.55	41.6	643
2'	.357	.643	415	57.7		
3'			419	59.2		
4'			393	58.9	58.6	715
4	.380	.620	418	61.9		
5			418	61.9		
6			418	61.4		
7			421	62.4	61.9	691
8	.453	.547	520	78.1		
9			491	80.8		
10			510	77.4	78.8	702
11	.500	.500	593	88.0		
12			590	88.8		
12'			590	87.8	88.2	705
13	.564	.436	694	94.8		
14			678	96.8		
15'			705	98.3	96.6	696
45	.648	.352	700	99.6		
46			727	103.0		
47			718	103.5		
48			740	105.0	102.8	697
42	.668	.332	687	105.0		
43			731	104.0		
14'			730	103.5		
16'			785	103.3		
17			769	103.0		
18			785	103.3		
19			777	106.0	104	702
28	.699	.301	699	102.5		
29			724	101.8	102.2	693
31	.784	.216	677	91.5		
32			684	93.7	92.6	697
33	.815	.185	554	80.0		
34			605	79.8		
35			596	81.4	80.4	654
36	.839	.161	532	76.8		
37			526	77.0	76.9	678
38	.916	.084	201	42.1		
39			198	49.7		
40			203	46.1	46.0	653

Av. k_1 689

$s = k_1[\text{CO}]^2[\text{O}_2]$, the curve so obtained is marked by the open circles in Fig. 3. This curve is seen to agree closely with the observed results.

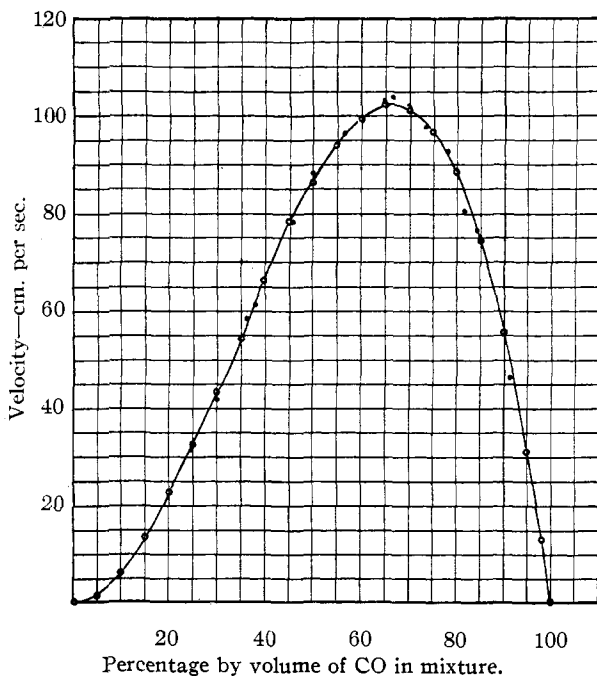

Fig. 3.—• Velocity observed. ○ Velocity = $k_1C_{\text{CO}}^2C_{\text{O}_2}$.

Remarks

A kinetic relation between the linear rate of movement of the zone in which the explosive reaction occurs and the concentrations of the active gases in which the zone is propagated, may prove indirectly of some value in the study of the rate of molecular transformation taking place within the flame, especially if the dimensions of the flame area, which appear to be sharply marked, could be determined with some accuracy during a reaction. Fundamentally, however, the method that has been described and the results given refer to the thermodynamics rather than to the kinetics of the reaction. The value of s is the linear rate at which an equilibrium condition is established. The method is concerned only with the initial and end conditions of an energy transformation as measured by gaseous volumes at constant pressure. The method takes no account of the way, usually complex, by which the reaction proceeds within the flame area. This fact may be shown by results already given. Fig. 3 shows the agreement between the observed value of s and a distribution curve for a tri-molecular reaction, $2\text{CO} + \text{O}_2 = 2\text{CO}_2$; yet this reaction is dependent

upon intermediate reactions probably of the form¹⁷ $\text{CO} + \text{H}_2\text{O} = \text{CO}_2 + \text{H}_2$ and $2\text{H}_2 + \text{O}_2 = 2\text{H}_2\text{O}$, so that the rate at which the reaction between carbon monoxide and oxygen completes itself must depend upon the rate at which the partial pressure of the water vapor present is maintained by the intermediate reaction.

If the partial pressure of the water vapor with which the explosive gases were saturated at their initial condition be gradually reduced while other

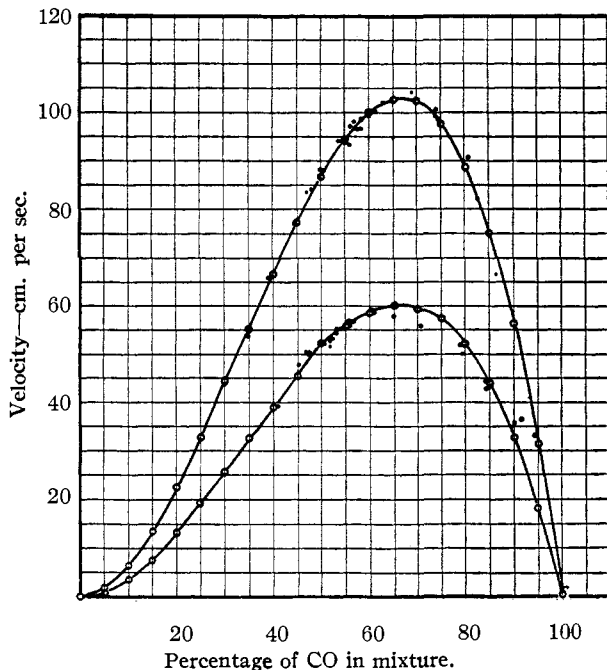

Fig. 4.—The effect of reduced water-vapor pressure on rate of flame movement.

conditions remain unchanged,¹⁸ it will be found that the rate of flame propagation will be reduced also until a point is reached where the explosive reaction can not be induced in the gases; yet throughout these changes it will be found that s remains proportional to the product of the initial concentration, $[\text{CO}]^2[\text{O}_2]$. The value of the proportionality factor k_1 decreases rapidly with a decrease in the partial pressure of the water vapor present. The upper curve of Fig. 4 gives the observed values of s for this reaction at initial atmospheric conditions and water-vapor saturation. The lower curve shows the values for s for the same conditions except that the gases

¹⁷ Nernst, "Theoretical Chemistry," Macmillan, 10th edition, 1923, p. 791.

¹⁸ The Bunsen-Gouy method (Refs. 3, 4, 5) employing a burner was made use of in these experiments, instead of the bubble.

are partially dried by chemical means. The value of k_1 for the upper curve is 692; for the lower, 405. If the gases are further dried by refrigeration and again brought to atmospheric conditions of temperature and pressure they cannot be exploded by a spark, although they will burn if again brought in contact with the oxygen and water vapor of the air.

The constant pressure p at which the reaction runs its course under the conditions imposed by the method just described is not the initial static pressure p_0 of the gases; but is their static pressure plus the impact pressure due to the linear rate at which the sphere of reaction is expanding,

$$p = p_0 + \frac{\rho}{2} s'^2 \quad (9)$$

where ρ is the initial density of the mixture of active gases. For values of s' not too near the velocity of sound in the gases it will be seen that the value of $(\rho/2)s'^2$ is small and may be negligible. But for values of s' above that of sound, it becomes the more important factor, because, under these circumstances, as Hugoniot¹⁹ has shown, the law of static adiabatic no longer applies—the pressure in the impact wave at the seat of reaction increases for velocities above that of sound much more rapidly than the square of s' . It is, therefore, the pressure at the seat of reaction and not that indicated at a point more or less remote that should be considered in determining the pressure condition of the reaction and its effect upon reaction rate.

Applying the law of Hugoniot instead of the simple impact expression given in Equation 9, Chapman,²⁰ Jouguet,²¹ Crussard,²² and Becker²³ have made extended analyses of the impact pressure conditions accompanying the flame when its velocity of propagation exceeds that of sound in the gases. These are conditions applying to the high rates of flame propagation met with in the Berthelot explosive wave,²⁴ sometimes referred to as detonation, where the reaction runs its course at a constant impact pressure of many atmospheres. The flame velocity under these conditions is found, as in the case of much lower constant pressures described in this paper, to be strictly constant and, for tubes above 10 mm. diameter, quite independent of a container. The maximum flame velocity of the carbon monoxide-oxygen explosive reaction as found by the method described in this paper is 104 cm. per second at a pressure of one atmosphere. The maximum explosive wave velocity was found by Berthelot to be 166,900 cm. per second. The constant impact pressure accompanying the flame at this velocity is, according to Jouguet, 15.5 atmospheres.

¹⁹ Hugoniot, *J. l'école polytech. Paris*, cahiers 57, 58 (1887).

²⁰ Chapman, *Phil. Mag.*, **47**, 90 (1899).

²¹ Jouguet, *J. Math.*, **1**, 347 (1905); **2**, 5 (1906).

²² Crussard, *Bull. soc. ind. min., St. Etienne*, [4] **6**, 1 (1907).

²³ Becker, *Z. Physik*, **8**, 321 (1923).

²⁴ Berthelot and Vieille, *Bull. soc. chim.*, **40**, 2 (1883).

The writer desires to express his gratitude to the National Advisory Committee for Aeronautics not only for generous financial support but also for continued interest and encouragement during an investigation of explosive gaseous reactions of which this paper is a partial report.

Summary

A condition under which the explosive gaseous reaction may run its course at constant pressure, thereby eliminating a variable factor affecting the concentrations of the explosive gases the flame is entering, may be closely realized in practice by holding temporarily the gases within a soap film container and firing the bubble from the center. This device functions as a bomb of constant pressure and thus provides the complement to the bomb of constant volume in the relation $pv = nRT$. Being transparent, it permits an accurate photographic time-volume record of the reaction to be secured. This record gives the initial volume v^0 of the active components of known concentrations, and, at the instant the action is completed, it gives the volume v^s of the equilibrium products which is the volume corresponding to the reaction constant

$$K = \frac{[A]^{n_1} [B]^{n_2} [C]^{n_3}}{[A']^{n'_1} [B']^{n'_2} [C']^{n'_3}}$$

Because the concentrations of the explosive gases that the flame is entering remain constant under the condition of constant pressure, it is found that the flame velocity under these conditions also remains constant during the reaction and that its value, s , is proportional to the product of the initial concentration of the gases,

$$s = k_1[A]^{n_1} [B]^{n_2} [C]^{n_3}$$

WASHINGTON, D. C.

[CONTRIBUTION FROM THE BUREAU OF METALLURGICAL RESEARCH, CARNEGIE INSTITUTE OF TECHNOLOGY]

THE CRYSTAL STRUCTURE OF MAGNESIUM PLUMBIDE

BY JAMES B. FRIAUF

RECEIVED MAY 3, 1926

PUBLISHED JULY 6, 1926

Magnesium is known to form intermetallic compounds with at least three elements in the fourth group of the periodic table, silicon,¹ tin² and lead.^{3,2a} The crystal structures of magnesium stannide, Mg₂Sn and of magnesium silicide, Mg₂Si, have been completely determined by Pauling⁴ and by Owens and Preston⁵ and that of magnesium plumbide, Mg₂Pb, has been

¹ Vogel, *Z. anorg. Chem.*, **61**, 46 (1909). Lebeau and Bossuet, *Rev. métal.*, **6**, 273 (1909).

² (a) Kurnakow and Stepanow, *Z. anorg. Chem.*, **46**, 177 (1905). (b) Grube, *ibid.*, **46**, 76 (1905).

³ Grube, *ibid.*, **44**, 117 (1905).

⁴ Pauling, *THIS JOURNAL*, **45**, 2777 (1923).

⁵ Owens and Preston, *Proc. Phys. Soc. London*, **36**, 341 (1924).